

Consigliata in circostanze dove l'operatore è impegnato in lavorazioni di grossi pezzi o dove si richiede lo spostamento ad ampio raggio della fonte di illuminamento.

G-LED

ACCESSORI



S11*

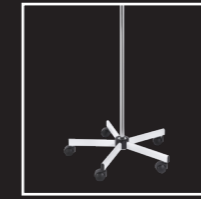

RL*



AMG

* l'accessorio richiede l'adattatore AMG

Potenza	9.5 W	9.5 W
Alimentazione	110-240 V	12-24 V ca/cc
Illuminamento a 50 cm	30.000 lux	30.000 lux
Temperatura di colore	4.600 K	4.600 K
Diametro del riflettore	90 mm	90 mm
Diametro del campo luminoso	190 mm	190 mm
Vita del prodotto	50.000 ore	50.000 ore
Movimento	Riflettore + 3 snodi	Riflettore + 3 snodi
Grado IP	IP 66	IP 66
Grado IK	IK 05	IK 05
Classe	III	III
Cavo di alimentazione	Trasformatore a spina con cavo AWG 2x21 ; spine intercambiabili	AWG 2x21
Fissaggio	4 viti su basetta	4 viti su basetta
Colorazioni	Grigio Martellato	Grigio Martellato
Codice per Ordine	G-LED-TR	G-LED-BT

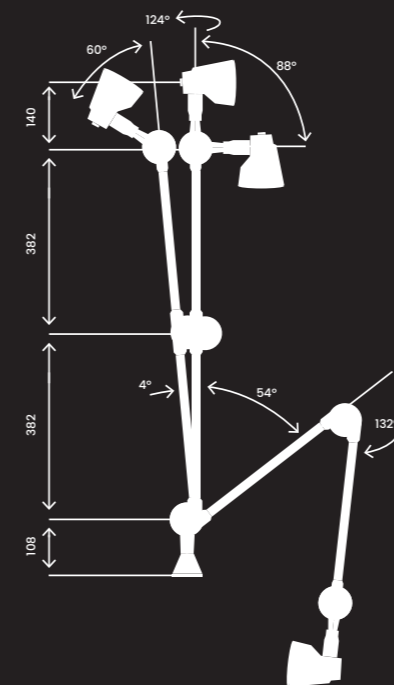

GM Grigio martellato

CODICE PER ORDINE

BASSA TENSIONE:

G-LED-BT

CON TRASFORMATORE:

G-LED-TR

